	<b>SERVICE BULLETIN</b>	
	<b>Flight Design GmbH</b> Sielminger Str. 51 D-70771 L.-Echterdingen Tel +49 (0)7021 / 80460-0 Fax +49 (0)7021 / 80460-69 E-Mail: <a href="mailto:airworthiness@flightdesign.com">airworthiness@flightdesign.com</a>	<b>SB-ASTM-CTLS-03</b> <b>Revision 00</b>

# SERVICE BULLETIN

## Rudder Centering Fork - Control Stop Replacement

### SB-ASTM-CTLS-03

## 1 Planning Information

### 1.1 Affected Aircraft

Type: CT

Model: CTLS

Serial Number: F-08-10-21, F-08-11-20, F-08-11-28, F-08-12-17, F-09-01-08, F-09-01-09, F-09-01-10, F-09-02-10, F-09-02-12, F-09-02-13, F-09-02-16, F-09-03-12, F-09-03-13, F-09-03-14, F-09-03-15, F-09-04-01, F-09-04-06, F-09-04-07, F-09-04-08, F-09-04-09, F-09-04-10, F-09-05-08, F-09-05-09, F-09-06-03, F-09-06-04, F-09-06-16, F-09-07-11, F-09-08-02, F-09-08-05, F-09-08-06, F-09-08-07, F-09-08-15, F-09-08-16, F-09-09-08

Applicable Countries: All Countries

### 1.2 Concurrent Documents

None

### 1.3 Reason

Service experience has shown that too much force on the pedals of the rudder/nose gear controls can lead to deformation of the rudder centering fork, even though the system fully fulfills all applicable certification requirements.

Overload can be achieved typically only during ground operation, such as control checks during engine run up, where the rudders are pushed intentionally against the stops. This can lead to deformation of the rudder centering fork, leading to incorrect function or jamming of the rudder control system.

Therefore Flight Design has decided to mandate changes to the system for all affected aircraft.

### 1.4 Subject

1. Inspect installed rudder centering fork for deformation. Exchange rudder centering fork if deformed.
2. Replace fork stop system device with a new design fork stop system.

	<b>SERVICE BULLETIN</b>	
	<b>Flight Design GmbH</b> Sielminger Str. 51 D-70771 L.-Echterdingen Tel +49 (0)7021 / 80460-0 Fax +49 (0)7021 / 80460-69 E-Mail: <a href="mailto:airworthiness@flightdesign.com">airworthiness@flightdesign.com</a>	<b>SB-ASTM-CTLS-03</b> <b>Revision 00</b>

## 1.5 Compliance

The inspection according chapter 3.2 is mandatory before the next flight.

If the inspection shows damage of the rudder centering fork, replacement of the rudder centering fork and installation of the new fork stop system according to chapter 3.3 is mandatory before next flight.

If there is no deformation, installation of the new fork stop system according to section 3.3 is mandatory to be performed within 6 months after issue of this SB. Until this step is completed, the inspection as by chapter 3.2 has to be repeated at every 100 hr inspection, or at any time when overload of the old fork stop is suspected.

**Warning:** Special attention is required while operating aircraft that have not yet been modified to the rudder stop plates (shown in [2]) or to the new fork stop system to prevent overloading.

## 1.6 Personnel Qualifications

National maintenance and inspection regulations as applicable for heavy maintenance apply.

For US LSA aircraft: Repairman, Light Sport Aircraft-Maintenance (RLSA-M) – holds a repairman certificate (light sport aircraft) with a maintenance rating, A&P, IA or an FAA repair station.

When allowed by national maintenance regulations, the initial inspection for deformation may be conducted by the Owner / Pilot.

## 1.7 Approval

Conduct of this SB must be inspected by an aircraft inspector as by the national applicable regulations for the country of registry of the aircraft.

Inspection and results must be noted in the aircraft logbook together with the result of the inspection, and with the name and qualification of the person conducting the task.

Installation of the new fork stop system must be documented in the aircraft logbook with name and qualification of the person conducting the task.

## 1.8 Weight and Center of Gravity

Not affected

## 1.9 References

- [1] CTLS Maintenance and Inspections Procedures Manual
- [2] SB-ASTM-CTLS-02

## 1.10 Superseded Documents

None

	<b>SERVICE BULLETIN</b>	
	<b>Flight Design GmbH</b> Sielminger Str. 51 D-70771 L.-Echterdingen Tel +49 (0)7021 / 80460-0 Fax +49 (0)7021 / 80460-69 E-Mail: <a href="mailto:airworthiness@flightdesign.com">airworthiness@flightdesign.com</a>	<b>SB-ASTM-CTLS-03</b> <b>Revision 00</b>

### 1.11 Contact Details

For further information on conduct of this SB, or to report any Safety of Flight or Service Difficulty issues contact your Distributor responsible for your country. Your Distributor can be located via the Flight Design website: [www.flightdesign.com](http://www.flightdesign.com) under "Dealer Location".

Specific contact in USA:

Flight Design USA  
 P.O. Box 325 South Woodstock, CT 06267  
 Tel: 860 963 7272 / Fax: 860 963 7152  
 Web: [www.flightdesignUSA.com](http://www.flightdesignUSA.com)  
 E-Mail: [airworthiness@flightdesignUSA.com](mailto:airworthiness@flightdesignUSA.com)

In cases where the local distributor is not known or available contact Flight Design GmbH directly: [airworthiness@flightdesign.com](mailto:airworthiness@flightdesign.com).

## 2 Resources

### 2.1 Materials

KF27200224 – New design rudder Stop system

KF27200223 – PVC Plate;

KF27200200 – Rudder centering fork (in the case if the fork is damaged);

Bolt DIN 912 M6x20 mm – grade 8.8 – 6 pcs;

Washer DIN 9021-6.4 mm VZ – 6 pcs;

Self-locking nut DIN 985-M6, regular – 8 pcs;

Bolt DIN 933 M6x30 mm – grade 8.8 – 2 pcs.

### 2.2 Manpower

Typically the procedure takes three hours to complete, including adjusting of rudder deflection.

### 2.3 Cost

The national Flight Design Distributor can supply you with the spare parts upon notification of the affected aircraft S/N. The local price will vary depending on the cost of shipping and duties.

## SERVICE BULLETIN



### Flight Design GmbH

Sielminger Str. 51  
D-70771 L.-Echterdingen  
Tel +49 (0)7021 / 80460-0  
Fax +49 (0)7021 / 80460-69  
E-Mail: [airworthiness@flightdesign.com](mailto:airworthiness@flightdesign.com)

### SB-ASTM-CTLS-03 Revision 00

Date of Initial Publication: **30-Nov-2009**  
Publication Date of this Revision: **30-Nov-2009**

## 3 Instructions

### 3.1 Nomenclature

Within this document reference is made to three variants of rudder stop devices, limiting the maximum rudder deflection on the aircraft. For clarification, the three variants are explained as follows:

#### 3.1.1 Old Fork Stop System

This is the rudder stop system that was installed to the CTLS affected by this SB ex factory. In this system the stop is provided to the rear end of the rudder centering fork, installed to the tunnel, below the instrument board. See following Fig. 1, 2 for illustration.



Fig. 1

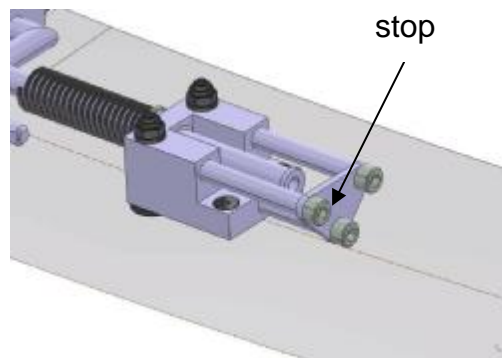

Fig. 2

This system is the system affected by this SB.

#### 3.1.2 New Fork Stop System

The new fork stop system provides a stop not to the rear end of the rudder centering fork, but to the thrust plates where the rudder centering fork contacts the bolt heads from the rudder pedal levers. The variant is clearly recognizable by the steel welded cage that provides the stops by means of adjustable bolts. See following Fig. 3 for illustration.

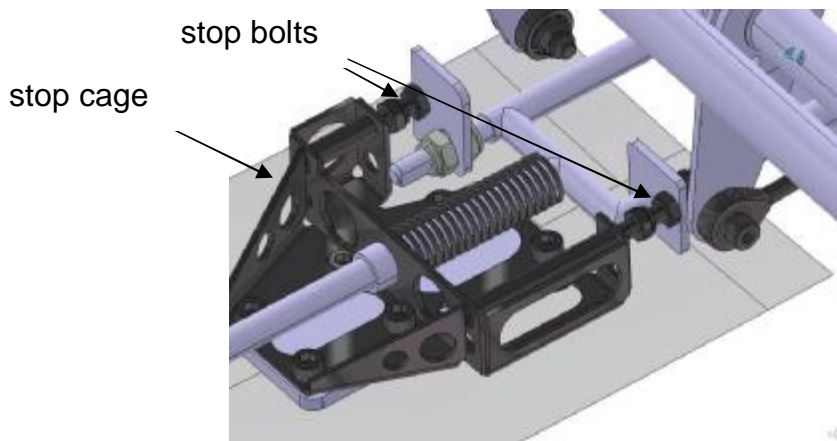



Fig. 3

	<b>SERVICE BULLETIN</b>	
	<b>Flight Design GmbH</b> Sielminger Str. 51 D-70771 L.-Echterdingen Tel +49 (0)7021 / 80460-0 Fax +49 (0)7021 / 80460-69 E-Mail: <a href="mailto:airworthiness@flightdesign.com">airworthiness@flightdesign.com</a>	<b>SB-ASTM-CTLS-03</b> <b>Revision 00</b>

This stop device represents the valid type design and is used in serial production at the time of issuing of this SB. Only on aircrafts where the Rudder Stop Plates as by 3.1.3 cannot be used, this new fork stop system must be installed following this SB.

### 3.1.3 Rudder Stop Plates

The rudder stop plates provide rudder stop not at the rudder centering fork. Aluminium stops, positioned to the control rods that connect the pedals with the nose gear steering, come to a stop against two stop plates welded to the big engine mount, in front of the firewall. See following Fig. 4 for illustration (only partially installed situation).

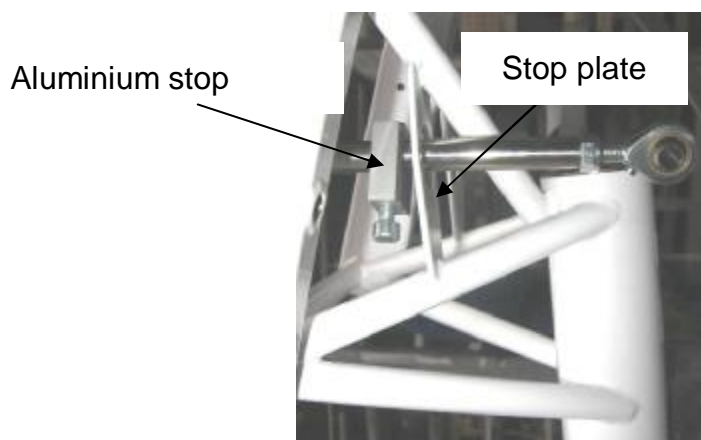

Fig. 4

This stop device represents the valid type design previous to the introduction of the old fork stop system. It has been replaced in production due to the more complex adjustment process, coupling with the rudder control rope pretension. On aircrafts where the welded stop plates are still available, this previous stop system shall be used again following SB [2], as it is easier and faster to be installed. However, aircraft S/N affected by this SB do not have the welded stop plates installed any more. Therefore this variant cannot be used any more for these aircraft.

### 3.2 Inspection

Following the procedures provided by [1], remove the lower center instrument panel. Move it to the side so that the rudder centering fork is accessible.

**Warning:** When removing or installing the lower center panel take special care not to damage the electric installation. Damages to the electric installation can result in short circuit and fire, seriously endangering the aircraft and the occupants.

The rudder centering fork is installed to the fuselage bottom, inside the tunnel, in the area below the instrument console.

Check if the rudder centering fork is not deformed, fork tubes are straight, and fork plates (small square plates shown on the fork, Fig. 5) are not bent or deformed. The correct configuration is shown on Fig. 5, 6;

## SERVICE BULLETIN



### Flight Design GmbH

Sielminger Str. 51  
D-70771 L.-Echterdingen  
Tel +49 (0)7021 / 80460-0  
Fax +49 (0)7021 / 80460-69  
E-Mail: [airworthiness@flightdesign.com](mailto:airworthiness@flightdesign.com)

### SB-ASTM-CTLS-03 Revision 00

Date of Initial Publication: **30-Nov-2009**  
Publication Date of this Revision: **30-Nov-2009**



Fig. 5



Fig. 6

With this information please use the feedback template to order the required spare parts at your FD Service Center or at your local FD distributor.

After the inspection reinstall the lower center instrument panel.

### 3.3 Installation of the New Rudder Stop System

#### 3.3.1 Open Lower Central Instrument Panel

Remove the lower center instrument panel – unscrew 4 bolts as by [1].

#### 3.3.2 Detach Nose Wheel Steering

Detach the pushrods of the nose wheel steering – unscrew two (2), DIN 912 M6 bolts from the left and right sides (Fig. 7, 8).

**Warning:** Keep pedals in neutral position during removal of the rods (Fig. 9). The spring force of the rudder centering fork will push the pedals towards the seats as soon as one of the pushrods is released. It is best done with one person holding the pedals and carefully releasing them after detachment of the pushrods.





## SERVICE BULLETIN

### Flight Design GmbH

Sielminger Str. 51  
D-70771 L.-Echterdingen  
Tel +49 (0)7021 / 80460-0  
Fax +49 (0)7021 / 80460-69

E-Mail: [airworthiness@flightdesign.com](mailto:airworthiness@flightdesign.com)

**SB-ASTM-CTLS-03**  
**Revision 00**

Date of Initial Publication: **30-Nov-2009**  
Publication Date of this Revision: **30-Nov-2009**



Fig. 7



Fig. 8



Fig. 9



## SERVICE BULLETIN

### Flight Design GmbH

Sielminger Str. 51  
D-70771 L.-Echterdingen  
Tel +49 (0)7021 / 80460-0  
Fax +49 (0)7021 / 80460-69

E-Mail: [airworthiness@flightdesign.com](mailto:airworthiness@flightdesign.com)

**SB-ASTM-CTLS-03**  
**Revision 00**

Date of Initial Publication: **30-Nov-2009**  
Publication Date of this Revision: **30-Nov-2009**

### 3.3.3 Remove Old Fork Stop System

The old fork stop system, that guides the rear end of the rudder centering fork, must be uninstalled when the rudder stop plates are installed. To do this, remove the three bushings, bolts and thrust plate shown in Fig 10 from the fork mount block. Unscrew three (3) DIN 912 M6 bolts (Fig. 10). Discard these parts.

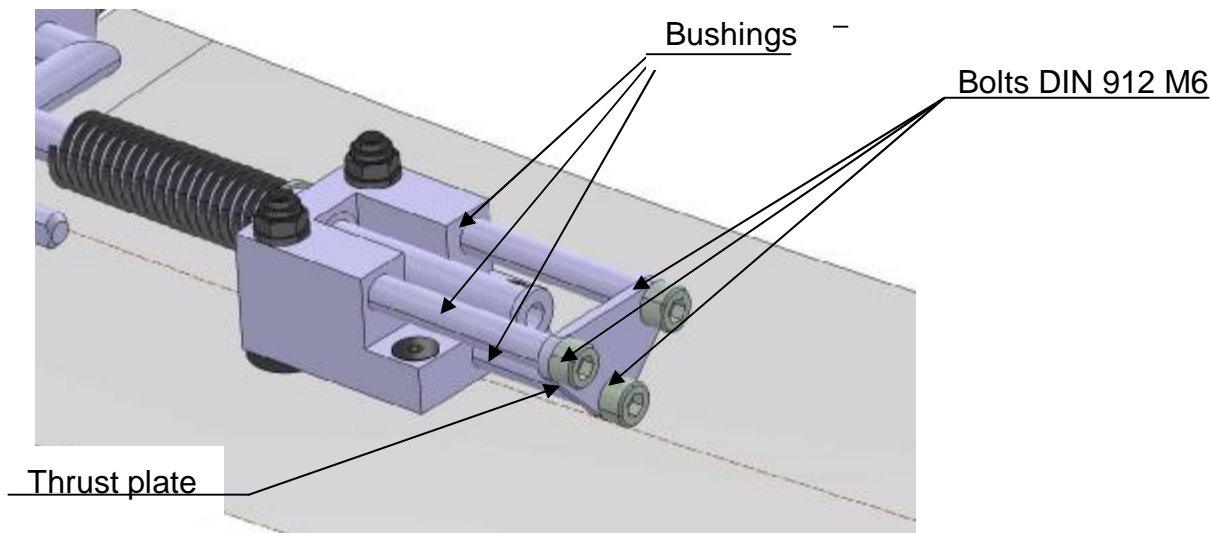

Fig. 10

Remove the rear aluminum fork mount block from the lower fuselage skin by unscrewing the 4 bolts as shown in Fig. 11.

**Warning:** The spring installed to the rudder centering fork provides a pretension to the system and will push the aluminium block to the rear, once all bolts are removed.

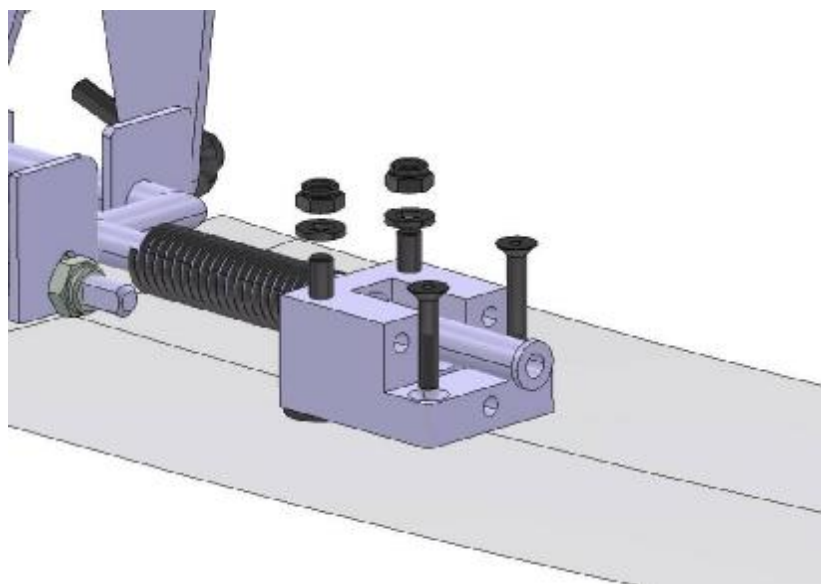



Fig. 11



	<b>SERVICE BULLETIN</b>	
	<b>Flight Design GmbH</b> Sielminger Str. 51 D-70771 L.-Echterdingen Tel +49 (0)7021 / 80460-0 Fax +49 (0)7021 / 80460-69 E-Mail: <a href="mailto:airworthiness@flightdesign.com">airworthiness@flightdesign.com</a>	<b>SB-ASTM-CTLS-03</b> <b>Revision 00</b>

The rudder centering fork can now be pulled out to the rear and removed from the aircraft. Remove dirt and old grease from the rudder centering fork and from its guides inside the fuselage.

### 3.3.4 Installation Preparation of New Fork Stop System

Bore out the four (4) existing holes from the outside bottom of fuselage to the new diameter Ø6mm.

Temporarily install PVC plate KF27200223 from the outside to the bottom fuselage using four (4) bolts (Fig. 12).

**Warning:** Installation must be exactly in the same position as the installation will be later on in the aircraft, so not turned upside down. When looking in direction of flight, the most forward hole on the left side must be rear of the most forward hole on the right side. Pay special attention, when drilling the holes you look from below In case of doubt use the new fork stop cage to cross check. See Fig 6.

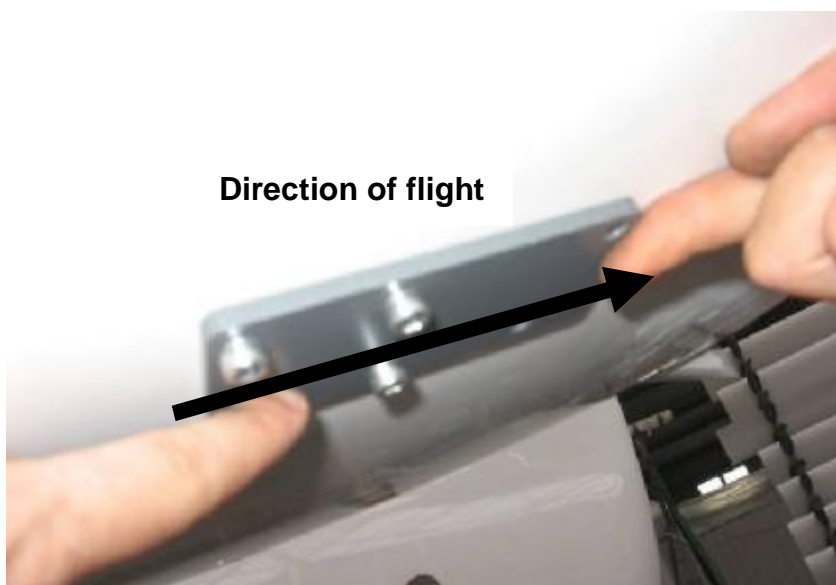

Fig. 12

Use the PVC plate as template to drill the two (2) front holes Ø6mm to the fuselage.

Remove polyamide bushing from the aluminum support that was uninstalled in step 3.3.3. Install this polyamide bushing to the guide hole of the new rudder stop device (Fig. 13).

## SERVICE BULLETIN



### Flight Design GmbH

Sielminger Str. 51  
D-70771 L.-Echterdingen  
Tel +49 (0)7021 / 80460-0  
Fax +49 (0)7021 / 80460-69  
E-Mail: [airworthiness@flightdesign.com](mailto:airworthiness@flightdesign.com)

### SB-ASTM-CTLS-03 Revision 00

Date of Initial Publication: **30-Nov-2009**  
Publication Date of this Revision: **30-Nov-2009**

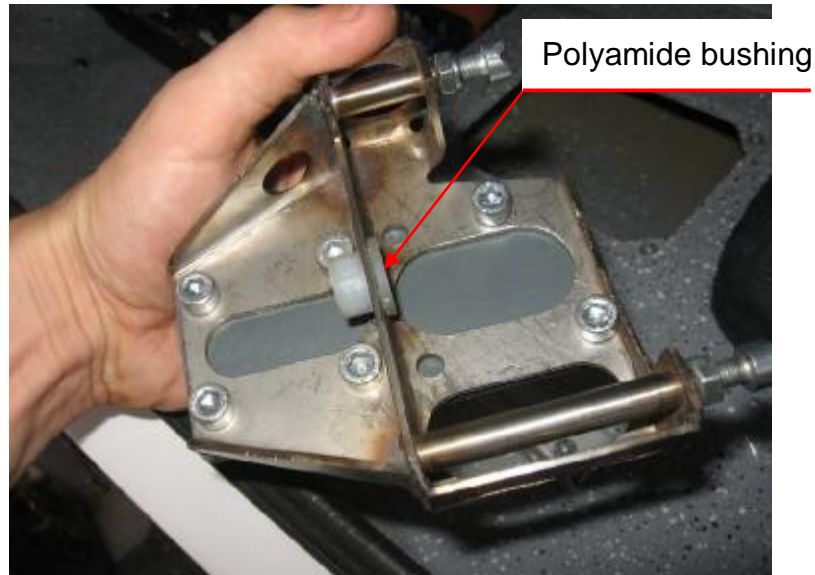

Fig. 13

### 3.3.5 Installation of New Fork Stop System

When the rudder centering fork is deformed, exchange now against a new rudder centering fork. Re-use the spring from the damaged rudder centering fork and make certain that the position of the left side fork plate (Fig. 5 above) is adjusted to the same position as on the original fork.

Grease the ends of the fork so that it will slide in the front fork guide and the rear mount block.

Take the new fork stop system cage and place the PVC plate on the lower side and insert the 6 attachment bolts (Fig 13).

Insert rear guide of the rudder centering fork to the new fork stop system cage as shown in Fig 14.

**Warning:** Install one (1) washer between the spring and polyamide bush (Fig. 14)

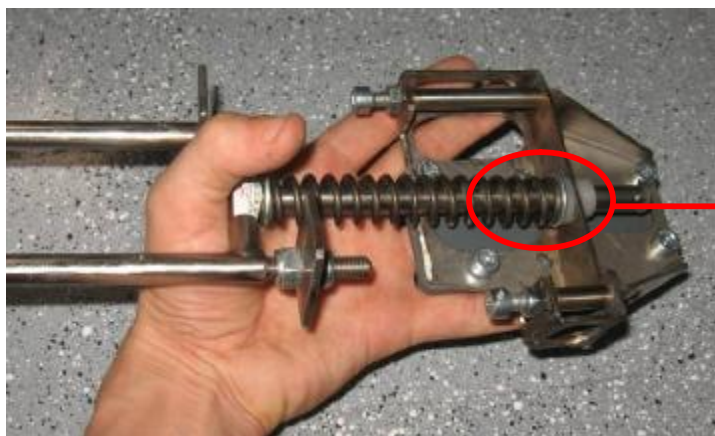

Washer

Fig. 14

## SERVICE BULLETIN



### Flight Design GmbH

Sielminger Str. 51  
D-70771 L.-Echterdingen  
Tel +49 (0)7021 / 80460-0  
Fax +49 (0)7021 / 80460-69  
E-Mail: [airworthiness@flightdesign.com](mailto:airworthiness@flightdesign.com)

### SB-ASTM-CTLS-03 Revision 00

Date of Initial Publication: **30-Nov-2009**  
Publication Date of this Revision: **30-Nov-2009**

Now the set of rudder centering fork and new fork stop system cage can be positioned into the fuselage. The fork is inserted to the front fork guide and the new fork stop system cage is attached to the six (6) attachment points on the fuselage floor (Fig. 15).

Install washers DIN 9021 6.3 mm from the outside of fuselage. Install new self-locking nuts M6 on each bolt. Apply tightening torque: 9 Nm.



Fig. 15

### 3.4 Rudder Deflection Adjustment

Adjustment of the rudder stops is achieved by changing the length of the stop bolts, inserted to the new fork stop system cage (Fig. 16). When deflected, the fork plates are pushed against these stop bolts. Changing both of the bolts allows increasing or decreasing the maximum rudder deflection.

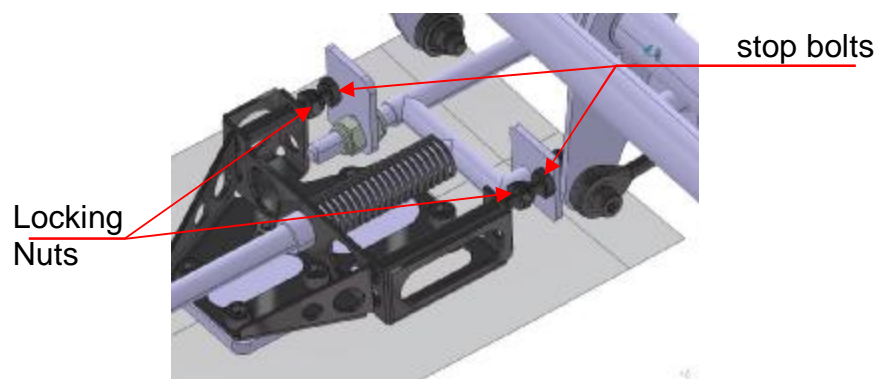

Fig. 16

**Warning:** The stops on both sides of the new system must be installed so that the stop at the side where the pedal is deflected touches the centering fork first or at the same time as the other side does. The opposite stop from the deflected pedal cannot touch first.

After finishing of the adjustment tighten the locking nuts (Fig 16) on the stop bolts.

## SERVICE BULLETIN



### Flight Design GmbH

Sielminger Str. 51  
D-70771 L.-Echterdingen  
Tel +49 (0)7021 / 80460-0  
Fax +49 (0)7021 / 80460-69  
E-Mail: [airworthiness@flightdesign.com](mailto:airworthiness@flightdesign.com)

**SB-ASTM-CTLS-03**  
**Revision 00**

Date of Initial Publication: **30-Nov-2009**  
Publication Date of this Revision: **30-Nov-2009**

### 3.4.1 Verification of rudder deflection

Maximum rudder deflection is measured at the lower trailing edge of the rudder as shown in Fig 17.

206-228mm (8-9 in)

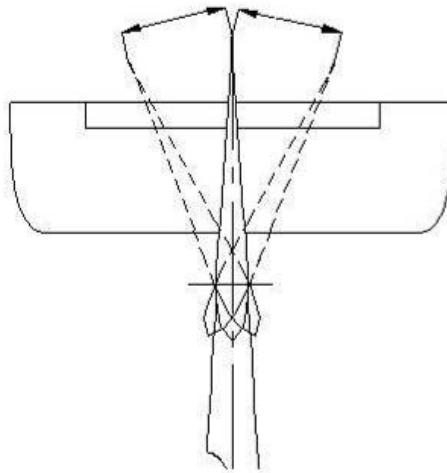

Fig. 17

To measure this deflection, position a pointer/reference marking the rear lower edge of the rudder in the neutral position. Then deflect the rudder by pushing the pedals up to the stop and measure distance between pointer and deflected rear edge of the rudder (Fig. 18).



Fig. 18

After finishing of the adjustment tighten the locking nuts (Fig 16) on the stop bolts.

### 3.4.2 Secure bolts

Mark all affected bolt and nut connections with Torque stripe lacquer.

## 4 Appendix

### 4.1 Changes to Previous Revision

Original Issue – no changes

	<b>SERVICE BULLETIN</b>	
	<b>Flight Design GmbH</b> Sielminger Str. 51 D-70771 L.-Echterdingen Tel +49 (0)7021 / 80460-0 Fax +49 (0)7021 / 80460-69 E-Mail: <a href="mailto:airworthiness@flightdesign.com">airworthiness@flightdesign.com</a>	<b>SB-ASTM-CTLS-03</b> <b>Revision 00</b>

#### 4.2 Feedback Template Flight Design

This form has to be used to coordinate with Flight Design the required spare parts and to communicate the completion of the SB listed in the header of this page.

Submission can be done by mail, Fax or as scanned copy per e-mail to Flight Design GmbH (see header of this page) or to your national Flight Design Distributor who will forward the information for you.

#### Information to obtain spare parts

Aircraft Type: CT  
 Model: CTLS  
 Serial Number: \_\_\_\_\_  
 Aircraft Owner, Name and Address: \_\_\_\_\_  
 \_\_\_\_\_  
 \_\_\_\_\_

The new centering fork is required      Yes       No

#### Confirmation of Completion

Conduct of this SB has been done at the following workshop:

\_\_\_\_\_

Responsible Mechanic:

\_\_\_\_\_

Date: \_\_\_\_\_      Location: \_\_\_\_\_      Signature: \_\_\_\_\_

**Warning:** As long as the form has not been submitted to Flight Design, this SB is considered not complied-with for the respective aircraft!