	SERVICE BULLETIN	
	Flight Design GmbH Sielminger Str. 51 D-70771 L.-Echterdingen Tel +49 (0)7021 / 80460-0 Fax +49 (0)7021 / 80460-69 E-Mail: airworthiness@flightdesign.com	SB-LTUL-CTLS-04 Revision 00
	Date of Initial Publication: 30-Nov-2009 Publication Date of this Revision: 30-Nov-2009	

SERVICE BULLETIN

Rudder Centering Fork - Control Stop Replacement

SB-LTUL-CTLS-04

1 Planning Information

1.1 Affected Aircraft

Type: CT

Model: CTLS

Serial Number: F-08-04-02, F-08-04-03, F-08-04-04, F-08-05-04, F-08-05-07, F-08-05-17, F-08-05-18, F-08-05-19, F-08-06-01, F-08-06-02, F-08-06-03, F-08-06-04, F-08-06-05, F-08-06-17, F-08-06-20, F-08-06-22, F-08-07-01, F-08-07-02, F-08-07-14, F-08-07-19, F-08-07-20, F-08-07-21, F-08-07-22, F-08-07-24, F-08-07-25, F-08-08-01, F-08-08-03, F-08-08-16, F-08-08-25, F-08-09-07, F-08-09-19, F-08-09-23, F-08-09-24, F-08-10-25

Applicable Countries: All Countries

1.2 Concurrent Documents

None

1.3 Reason

Service experience has shown that too much force on the pedals of the rudder/nose gear controls can lead to deformation of the rudder centering fork, even though the system fully fulfills all applicable certification requirements.

Overload can be achieved typically only during ground operation, such as control checks during engine run up, where the rudders are pushed intentionally against the stops. This can lead to deformation of the rudder centering fork, leading to incorrect function or jamming of the rudder control system.

Therefore Flight Design has decided to mandate changes to the system for all affected aircrafts.

1.4 Subject

1. Inspect installed rudder centering fork for deformation. Exchange rudder centering fork if deformed.
2. Install rudder stop plates instead of fork stop system device or, if not possible on the individual aircraft, replace with a new design fork stop system.

	SERVICE BULLETIN	
	Flight Design GmbH Sielminger Str. 51 D-70771 L.-Echterdingen Tel +49 (0)7021 / 80460-0 Fax +49 (0)7021 / 80460-69 E-Mail: airworthiness@flightdesign.com	SB-LTUL-CTLS-04 Revision 00
	Date of Initial Publication: 30-Nov-2009 Publication Date of this Revision: 30-Nov-2009	

1.5 Compliance

The inspection according chapter 3.2 is mandatory before the next flight.

If the inspection shows damage of the rudder centering fork, replacement of the rudder centering fork according to Chapter 3.4 and installation of the rudder stop plates according to chapter 3.3 is mandatory before next flight.

If there is no deformation, installation of the rudder stop plates or the new fork stop system according to section 3.3 is mandatory to be performed within 6 months after issue of this SB. Until this step is completed, the inspection as by chapter 3.2 has to be repeated at every 100 hr inspection, or at any time when overload of the old fork stop is suspected.

Warning: Special attention is required while operating aircraft that have not yet been modified to the rudder stop plates or to the new fork stop system (shown in [1]) to prevent overloading.

1.6 Personnel Qualifications

National maintenance and inspection regulations as applicable for heavy maintenance apply.

When allowed by national maintenance regulations, the initial inspection for deformation may be conducted by the Owner / Pilot.

1.7 Approval

Conduct of this SB must be inspected by an aircraft inspector as by the national applicable regulations for the country of registry of the aircraft.

Inspection and results must be noted in the aircraft logbook together with the result of the inspection, and with the name and qualification of the person conducting the task.

Installation of the stops must be documented in the aircraft logbook with name and qualification of the person conducting the task.

1.8 Weight and Center of Gravity

Not affected

1.9 References

[1] SB-LTUL-CTLS-05

1.10 Superseded Documents

None

	SERVICE BULLETIN	
	Flight Design GmbH Sielminger Str. 51 D-70771 L.-Echterdingen Tel +49 (0)7021 / 80460-0 Fax +49 (0)7021 / 80460-69 E-Mail: airworthiness@flightdesign.com	SB-LTUL-CTLS-04 Revision 00
		Date of Initial Publication: 30-Nov-2009 Publication Date of this Revision: 30-Nov-2009

1.11 Contact Details

For further information on conduct of this SB, or to report any Safety of Flight or Service Difficulty issues contact your Distributor responsible for your country. Your Distributor can be located via the Flight Design website: www.flightdesign.com under "Dealer Location".

In cases where the local distributor is not known or available contact Flight Design GmbH directly: airworthiness@flightdesign.com.

2 Resources

2.1 Materials

KA4010004_1 – Original design rudder stop for nose wheel pushrods – 2 pcs;

KA4010009 – Rubber stop pad – 2 pcs;

KF27200200 – Rudder centering fork (only if the fork is damaged);

Bolt DIN 912 M6x20 mm – grade 8.8 – 2 pcs.

2.2 Manpower

Typically the procedure takes two hours to complete, including adjusting of rudder deflection.

2.3 Cost

The national Flight Design Distributor can supply you with the spare parts upon notification of the affected aircraft S/N. The local price will vary depending on the cost of shipping and duties.



Flight Design GmbH

Sielminger Str. 51
D-70771 L.-Echterdingen
Tel +49 (0)7021 / 80460-0
Fax +49 (0)7021 / 80460-69

E-Mail: airworthiness@flightdesign.com

SB-LTUL-CTLS-04
Revision 00

Date of Initial Publication: **30-Nov-2009**
Publication Date of this Revision: **30-Nov-2009**

3 Instructions

3.1 Nomenclature

Within this document reference is made to three variants of rudder stop devices, limiting the maximum rudder deflection on the aircraft. For clarification, the three variants are explained as follows:

3.1.1 Old Fork Stop System

This is the rudder stop system that was installed to the CTLS affected by this SB ex factory. In this system the stop is provided to the rear end of the rudder centering fork, installed to the tunnel, below the instrument board. See following Fig. 1 and Fig. 2 for illustration.



Fig. 1

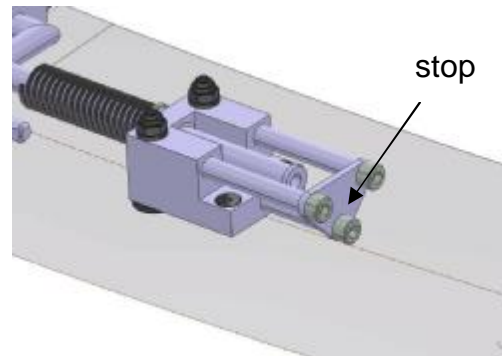

Fig. 2

This system is the system affected by this SB.

3.1.2 New Fork Stop System

The new fork stop system provides a stop not to the rear end of the rudder centering fork, but to the thrust plates where the rudder centering fork contacts the bolt heads from the rudder pedal levers. The variant is clearly recognizable by the steel welded cage that provides the stops by means of adjustable bolts. See following Fig. 3 for illustration.

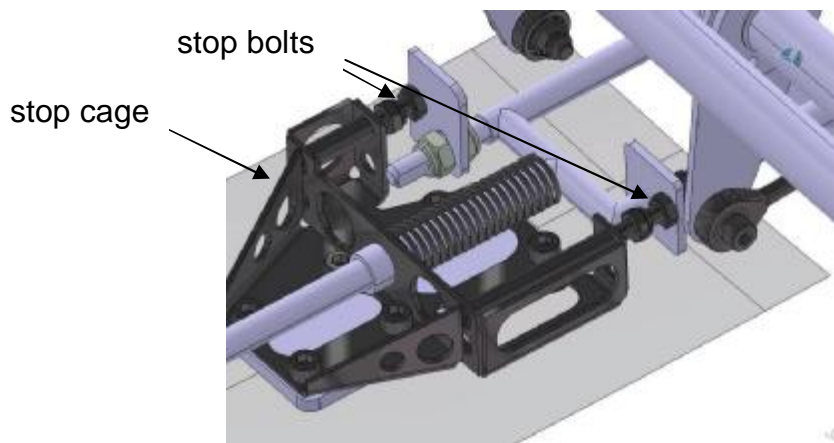



Fig. 3

	SERVICE BULLETIN	
	Flight Design GmbH Sielminger Str. 51 D-70771 L.-Echterdingen Tel +49 (0)7021 / 80460-0 Fax +49 (0)7021 / 80460-69 E-Mail: airworthiness@flightdesign.com	SB-LTUL-CTLS-04 Revision 00
	Date of Initial Publication: 30-Nov-2009 Publication Date of this Revision: 30-Nov-2009	

This stop device represents the valid type design and is used in serial production at the time of issuing of this SB. Only on aircrafts where the Rudder Stop Plates as by 3.1.3 cannot be used, this new fork stop system must be installed following SB [1].

3.1.3 Rudder Stop Plates

The rudder stop plates provide rudder stop not at the rudder centering fork. Aluminium stops, positioned to the control rods that connect the pedals with the nose gear steering, come to a stop against two stop plates welded to the big engine mount, in front of the firewall. See following Fig. 4 for illustration (only partially installed situation).

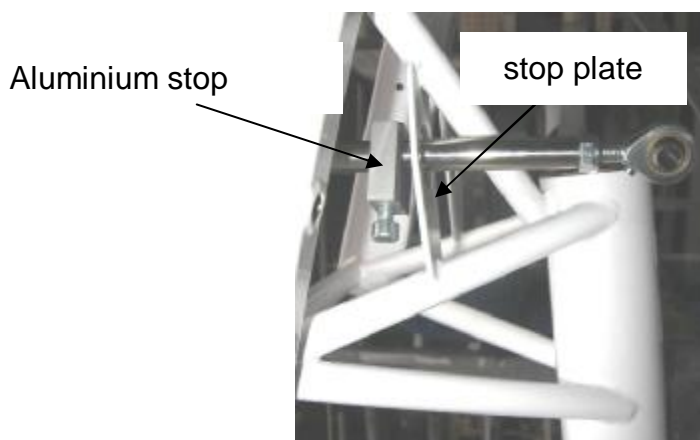

Fig. 4

This stop device represents the valid type design previous to the introduction of the old fork stop system. It has been replaced in production due to the more complex adjustment principle, coupling with the rudder control rope pretension. On aircrafts where the welded stop plates are still available, this previous stop system shall be used again as it is easier and faster to be installed. The modification procedure is provided by this SB.

3.2 Inspection

Remove the lower center instrument panel. Move it to the side so that the rudder centering fork is accessible.

Warning: When removing or installing the lower center panel take special care not to damage the electric installation. Damages to the electric installation can result in short circuit and fire, seriously endangering the aircraft and the occupants.

The rudder centering fork is installed to the fuselage bottom, inside the tunnel, in the area below the instrument console.

Check the following details specifically:

1. The rudder centering fork is not deformed, fork tubes are straight, and fork plates (small square plates shown on the fork, Fig. 5) are not bent or deformed. The correct configuration is shown on Fig. 5, 6;



SERVICE BULLETIN

Flight Design GmbH

Sielminger Str. 51
D-70771 L.-Echterdingen
Tel +49 (0)7021 / 80460-0
Fax +49 (0)7021 / 80460-69

E-Mail: airworthiness@flightdesign.com

SB-LTUL-CTLS-04 Revision 00

Date of Initial Publication: **30-Nov-2009**
Publication Date of this Revision: **30-Nov-2009**

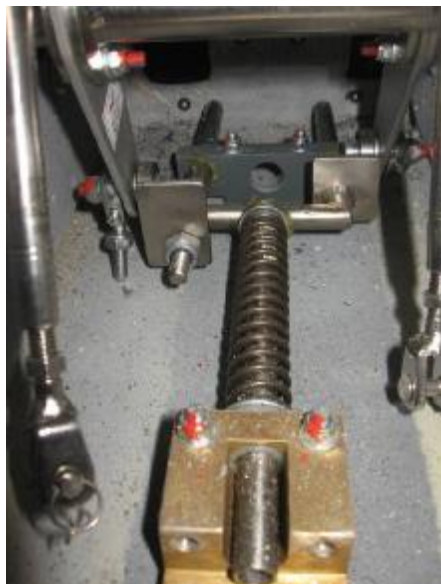

Fig. 5



Fig. 6

The engine mount is equipped with welded stop plates (Fig. 7);



Fig.7

When deformation is detected at the rudder centering fork, this fork must be exchanged.

When the welded stop plates are available, the stop system shall be changed towards the Rudder Stop Plates variant.

Warning: If your engine mount does not have the welded stop plates, SB [1] applies instead of all following procedures!

	SERVICE BULLETIN	
	Flight Design GmbH Sielminger Str. 51 D-70771 L.-Echterdingen Tel +49 (0)7021 / 80460-0 Fax +49 (0)7021 / 80460-69 E-Mail: airworthiness@flightdesign.com	SB-LTUL-CTLS-04 Revision 00

With this information please use the feedback template to order the required spare parts at your FD Service Center or at your local FD distributor.

After the inspection reinstall the lower center instrument panel.

3.3 Installation of the Rudder Stop Plates

3.3.1 Open Lower Central Instrument Panel

Remove the lower center instrument panel – unscrew 4 bolts.

3.3.2 Detach Nose Wheel Steering

Detach the pushrods of the nose wheel steering – unscrew two (2), DIN 912 M6 bolts from the left and right sides (Fig. 8, 9).

Warning: Keep pedals in neutral position during removal of the rods (Fig. 10). The spring force of the rudder centering fork will push the pedals towards the seats as soon as one of the pushrods is released. It is best done with one person holding the pedals and carefully releasing them after detachment of the pushrods.



Fig. 8



Fig. 9

SERVICE BULLETIN



Flight Design GmbH

Sielminger Str. 51
D-70771 L.-Echterdingen
Tel +49 (0)7021 / 80460-0
Fax +49 (0)7021 / 80460-69
E-Mail: airworthiness@flightdesign.com

SB-LTUL-CTLS-04
Revision 00

Date of Initial Publication: **30-Nov-2009**
Publication Date of this Revision: **30-Nov-2009**



Fig. 10

3.3.3 Remove Pushrods

Unscrew pushrods from the cockpit side in the tunnel (Fig. 11). To loosen pushrods, hold self-locking stop nut on the rod end bearing with a suitable wrench. Do not change the position of the self-locking stop nut on the rod end as this will be the adjustment guide for the re-installation later.

Pull the pushrods out of the leather dust covers installed to the firewall.

Warning: Don't damage the rods during removal.

Warning: Mark the pushrods properly and do not mix up left and right side pushrod.

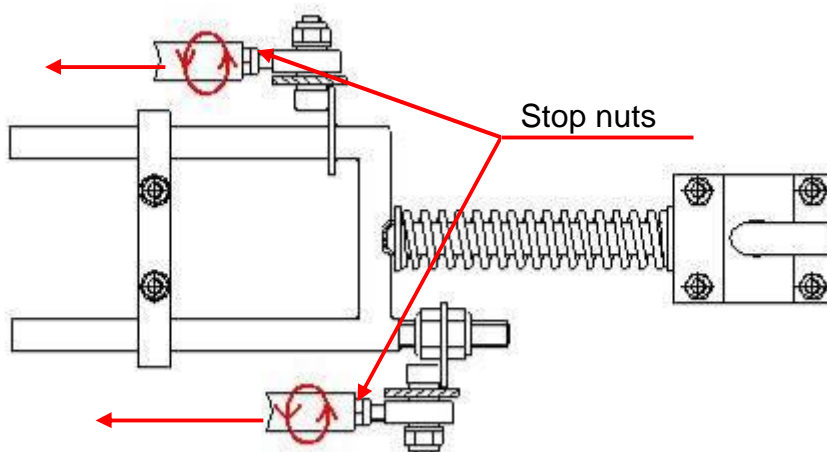

Fig. 11

3.3.4 Install Aluminum Stops

Slide new fork stops with glued rubber pads onto the pushrods (Fig. 12). Fork stops must be located between the welded stop plates (shown in Fig. 7 and below) and the dust covers



SERVICE BULLETIN

Flight Design GmbH

Sielminger Str. 51
D-70771 L.-Echterdingen
Tel +49 (0)7021 / 80460-0
Fax +49 (0)7021 / 80460-69
E-Mail: airworthiness@flightdesign.com

SB-LTUL-CTLS-04
Revision 00

Date of Initial Publication: **30-Nov-2009**
Publication Date of this Revision: **30-Nov-2009**

at the pass-through hole on the firewall, the rubber pad facing forward, toward the welded stop plate of the engine mount.

Loosely thread in the two (2) DIN 912 M6x20 bolts into the Aluminium stops, but do not tighten them yet before re-installation and adjustment (Fig. 13).



Fig. 12

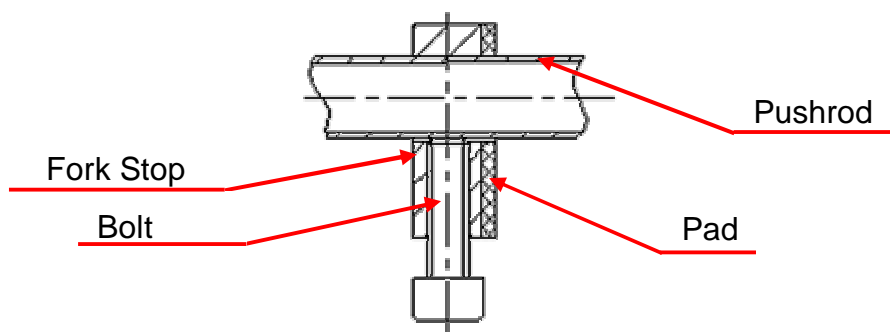

Fig. 13

3.3.5 Re-Install Pushrods

Insert the pushrods back through the dust covers in the firewall. Thread the pushrods back to the stop nuts of the rod end bearings (that were left in position, see Fig. 11) on the cabin side of the firewall. After threading the pushrod back on, the rod end bearings on the engine side of the firewall must be aligned vertically, so that they match the nose wheel steering again. Tighten the stop nuts (Fig. 11) in this correct position.

3.3.6 Re-connect Nose Wheel Steering

Re-install the pushrods using two (2), DIN 912 M6 bolts from left and right side. As the rudder centering device will again push the pedals towards the seat, this is easiest done with a second person pushing the pedals forward, so that the bolts can be installed easy.

Apply service-removable thread locking liquid to bolt threads (such as Loctite 243).

Apply tightening torque: 9 Nm.

3.3.7 Remove Old Fork Stop System

The old fork stop system, that guides the rear end of the rudder centering fork, must be uninstalled when the rudder stop plates are installed. To do this, remove the three bushings, bolts and thrust plate shown in Fig. 14 from the fork mount block. Unscrew three (3) DIN 912 M6 bolts (Fig. 14). Discard these parts.

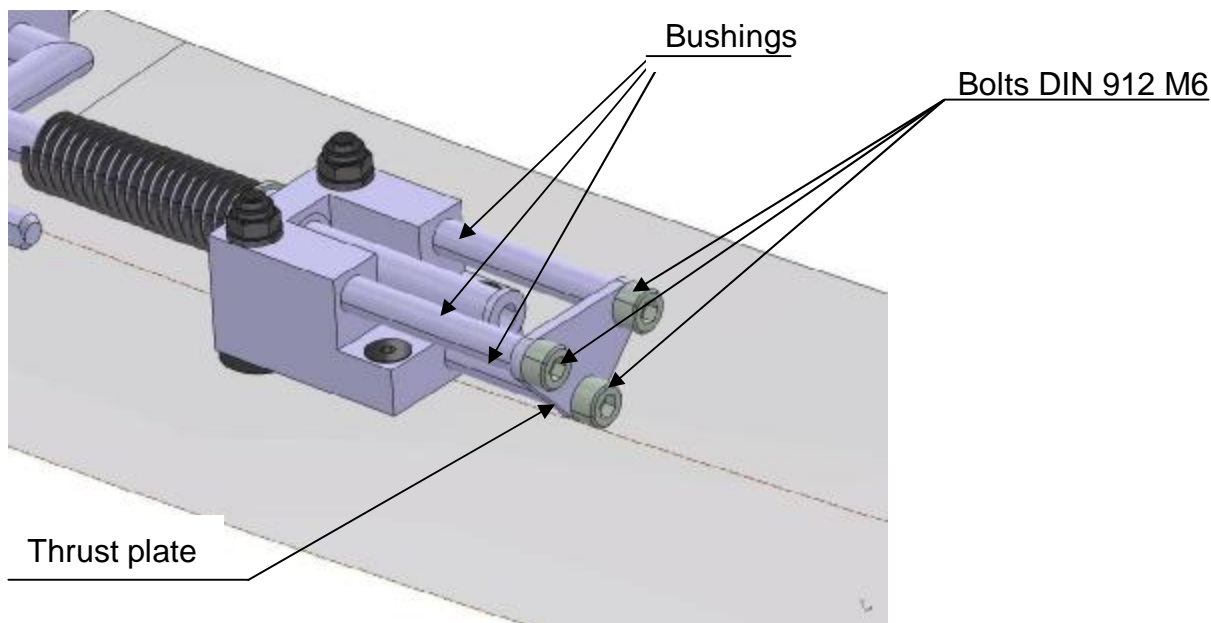

Fig. 14

3.4 Replacement of the Rudder Centering Fork

This chapter must be complied with only when a deformation has been detected on the rudder centering fork.

Warning: When no deformation has been detected during the inspection under Chapter 3.2, the instructions in this Chapter 3.4 can be skipped. In this case continue with chapter 3.5.

Remove the rear aluminum fork mount block from the lower fuselage skin by unscrewing the 4 bolts as shown in Fig. 15.

Warning: The spring installed to the rudder centering fork provides a pretension to the system and will push the aluminium block to the rear, once all bolts are removed.

SERVICE BULLETIN



Flight Design GmbH

Sielminger Str. 51
D-70771 L.-Echterdingen
Tel +49 (0)7021 / 80460-0
Fax +49 (0)7021 / 80460-69
E-Mail: airworthiness@flightdesign.com

SB-LTUL-CTLS-04
Revision 00

Date of Initial Publication: **30-Nov-2009**
Publication Date of this Revision: **30-Nov-2009**

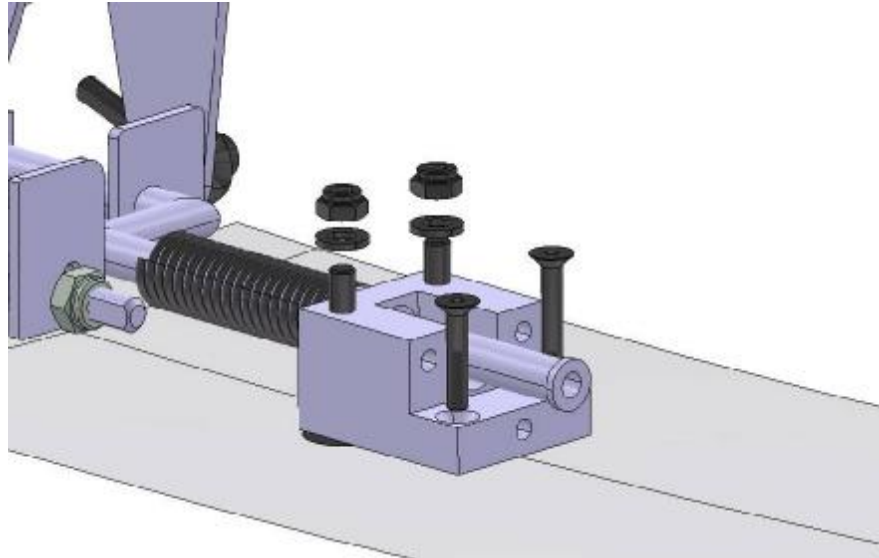

Fig. 15

Now the damaged rudder centering fork can be pulled out to the rear and removed from the aircraft.

Make certain the position of the left side fork plate (Fig. 5 and Fig. 15, above, left side) is adjusted to the same position as on the original fork.

Remove the spring from the damaged rudder centering fork and install it to the new centering fork.

Grease the ends of the fork so that it will slide in the front fork guide and the rear mount block.

Install the new rudder centering fork to the front fork guide.

Re-install the aluminum fork mount block removed in step 3.3.7.

Re-attach the aluminium fork mount block with the same 4 bolts. Replace the self locking nuts with new parts. Apply tightening torque: 5.5 Nm.

SERVICE BULLETIN



Flight Design GmbH

Sielminger Str. 51
D-70771 L.-Echterdingen
Tel +49 (0)7021 / 80460-0
Fax +49 (0)7021 / 80460-69
E-Mail: airworthiness@flightdesign.com

SB-LTUL-CTLS-04
Revision 00

Date of Initial Publication: **30-Nov-2009**
Publication Date of this Revision: **30-Nov-2009**

3.5 Rudder Deflection Adjustment

Following this modification the maximum rudder deflection can be adjusted by moving the Aluminium plates on the pushrods.

3.5.1 Verification of rudder deflection

Maximum rudder deflection is measured at the lower trailing edge of the rudder as shown in Fig 16.

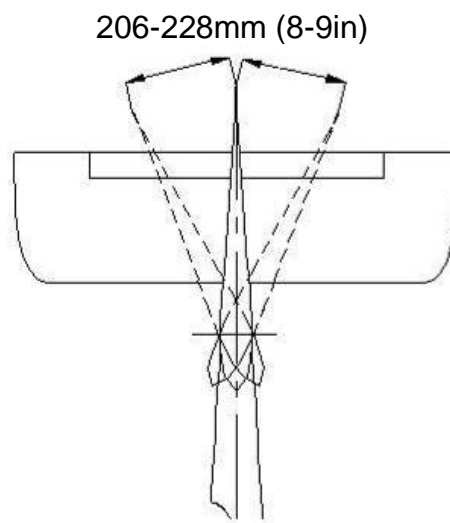



Fig. 16

To measure this deflection, position a pointer/reference marking the rear lower edge of the rudder in the neutral position. Then deflect the rudder by pushing the pedals up to the stop and measure distance between pointer and deflected rear edge of the rudder (Fig. 17).



Fig. 17

Move the position of the Fork Stop Plates as necessary to achieve the correct rudder deflection. When correct deflection is confirmed, tighten the two (2) M6 bolts on the stops to 4 Nm.

	SERVICE BULLETIN	
	Flight Design GmbH Sielminger Str. 51 D-70771 L.-Echterdingen Tel +49 (0)7021 / 80460-0 Fax +49 (0)7021 / 80460-69 E-Mail: airworthiness@flightdesign.com	SB-LTUL-CTLS-04 Revision 00

3.5.2 Checking of Stop Plate Overlap:

Verify that the overlap of the Aluminium stops with the welded stop plate on the engine mount is at least 2 mm (0.1 in) on the edge of the hole on the welded plate (Fig. 18).

If this is not the case, correct by rotating the Fork Stop. If this does not rectify the issue, contact Flight Design with a picture of the situation and ask for individual guidance.



Fig. 18

3.5.3 Secure bolts

Mark all affected bolt and nut connections with Torque stripe lacquer.

4 Appendix

4.1 Changes to Previous Revision

Original Issue – no changes

	SERVICE BULLETIN	
	Flight Design GmbH Sielminger Str. 51 D-70771 L.-Echterdingen Tel +49 (0)7021 / 80460-0 Fax +49 (0)7021 / 80460-69 E-Mail: airworthiness@flightdesign.com	SB-LTUL-CTLS-04 Revision 00
	Date of Initial Publication: 30-Nov-2009 Publication Date of this Revision: 30-Nov-2009	

4.2 Feedback Template Flight Design

This form has to be used to coordinate with Flight Design the required spare parts and to communicate the completion of the SB listed in the header of this page.

Submission can be done by mail, Fax or as scanned copy per e-mail to Flight Design GmbH (see header of this page) or to your national Flight Design Distributor who will forward the information for you.

Information to obtain spare parts

Aircraft Type: CT
 Model: CTLS
 Serial Number: _____
 Aircraft Owner, Name and Address: _____

The engine mount is equipped with stop plates Yes No

The new rudder centering fork is required Yes No

Confirmation of Completion

Conduct of this SB has been done at the following workshop:

Responsible Mechanic:

Date: _____ Location: _____ Signature: _____

Warning: As long as the form has not been submitted to Flight Design, this SB is considered not complied-with for the respective aircraft.