	<b>Service NOTIFICATION</b>	
	<b>Flight Design GmbH</b> Sielminger Str. 65 D-70771 L.-Echterdingen Tel +49 (0)711 90287-0 Fax +49 (0)711 90287-99 E-Mail: <a href="mailto:info@flightdesign.com">info@flightdesign.com</a>	<b>SN-LTUL-CT2k-06</b> <b>Revision 1</b>
		Date of Initial Publication: <b>19-Dec-2009</b> Publication Date of this Revision: <b>19-Dec-2009</b>

# Service NOTIFICATION

## CT2k MTOW increase for German Certification

### SN-LTUL-CT2k-06

#### 1 Planning Information

##### 1.1 Affected Aircraft

Type: CT  
 Model: CT2k  
 Serial Number: All serial numbers  
 Applicable Countries: All Countries where LTF-UL standards are in effect

##### 1.2 Concurrent Documents

None

##### 1.3 Reason

Re- issue of existing document in order to implement it to the new Service document numbering system

##### 1.4 Subject

All information see paragraph 3

##### 1.5 Compliance

All information see paragraph 3

##### 1.6 Personnel Qualifications

All information see paragraph 3

##### 1.7 Approval

All information see paragraph 3

##### 1.8 Weight and Center of Gravity

All information see paragraph 3

##### 1.9 References

All information see paragraph 3

##### 1.10 Superseded Documents

TM 1

	<b>Service NOTIFICATION</b>	
	<b>Flight Design GmbH</b> Sielminger Str. 65 D-70771 L.-Echterdingen Tel +49 (0)711 90287-0 Fax +49 (0)711 90287-99 E-Mail: <a href="mailto:info@flightdesign.com">info@flightdesign.com</a>	<b>SN-LTUL-CT2k-06</b> <b>Revision 1</b>
		Date of Initial Publication: <b>19-Dec-2009</b> Publication Date of this Revision: <b>19-Dec-2009</b>

### 1.11 Contact Details

For further information or to report any Safety of Flight or Service Difficulty issues contact your Distributor responsible for your country.

Specific contact in USA:

Flight Design USA  
 P.O. Box 325 South Woodstock, CT 06267  
 Tel: 860 963 7272 / Fax: 860 963 7152  
 Web: [www.flightdesignUSA.com](http://www.flightdesignUSA.com)  
 E-Mail: [airworthiness@flightdesignUSA.com](mailto:airworthiness@flightdesignUSA.com)

For all other countries and in cases where the local distributor is not known or available contact Flight Design GmbH directly.

## 2 Resources

### 2.1 Materials

All information see paragraph 3

### 2.2 Manpower

All information see paragraph 3

### 2.3 Cost

All information see paragraph 3

## 3 Instructions

The following is the 1:1 copy of the existing document following the old numbering system.



## Service NOTIFICATION

### Flight Design GmbH

Sielminger Str. 65  
D-70771 L.-Echterdingen  
Tel +49 (0)711 90287-0  
Fax +49 (0)711 90287-99

E-Mail: [info@flightdesign.com](mailto:info@flightdesign.com)

SN-LTUL-CT2k-06

Revision 1

Date of Initial Publication: **19-Dec-2009**  
Publication Date of this Revision: **19-Dec-2009**

## FLIGHT DESIGN

### Technische Mitteilung Nr. 1

Vom 30.09.2003

### Flight Design CT2K Auflastung auf 472,5 kg

Für die Gültigkeit der Auflastung für die bis zum 30.09.2003 ausgelieferten CT2K auf 472,5 kg sind folgende Maßnahmen durchzuführen:

1. Es sind zusätzlichen zwei Gurte für das Rettungsgerät um den Hauptholm zu legen (siehe beiliegende Zeichnung).
2. Es ist das Handbuch auf CT2K Version 3 zu ersetzen
3. Es sind die übrigen Bordpapier inklusive Wägebericht auf 472,5 kg zu ändern
4. Es sind die Fahrtmesserfarbmarkierungen entsprechend dem Handbuch CT2K V3 zu ändern.

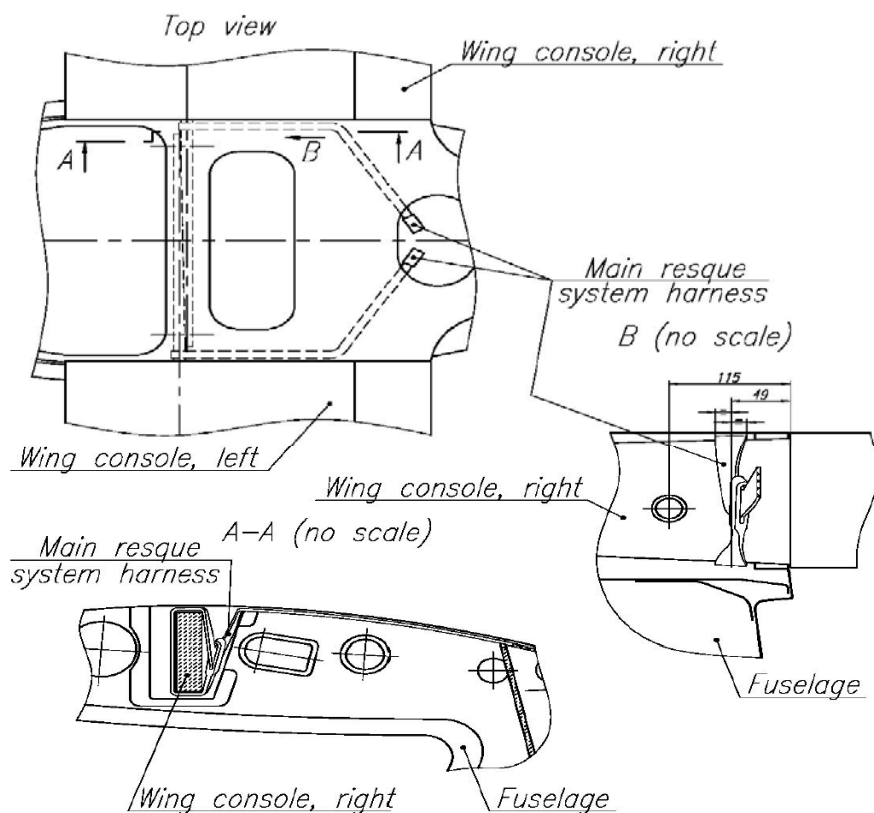

	<b>Service NOTIFICATION</b>	
	<b>Flight Design GmbH</b> Sielminger Str. 65 D-70771 L.-Echterdingen Tel +49 (0)711 90287-0 Fax +49 (0)711 90287-99 E-Mail: <a href="mailto:info@flightdesign.com">info@flightdesign.com</a>	<b>SN-LTUL-CT2k-06</b> <b>Revision 1</b>
	Date of Initial Publication: <b>19-Dec-2009</b> Publication Date of this Revision: <b>19-Dec-2009</b>	

## 4 Appendix

### 4.1 Changes to Previous Revision

No content changes – re-issue of existing document to new numbering system

### 4.2 Feedback Template Flight Design

All information see paragraph 3